

PLAN VIEW
SCALE: 1/4"=1'-0"

ELECTRIC BLOWER PACK SPECIFICATIONS

MOTOR RPM/HP	BLOWER RPM	BLOWER HP	BLOWER CFM @ 15PSI
3600/40	4000	48.5	420
3600/60	4000	74.1	620

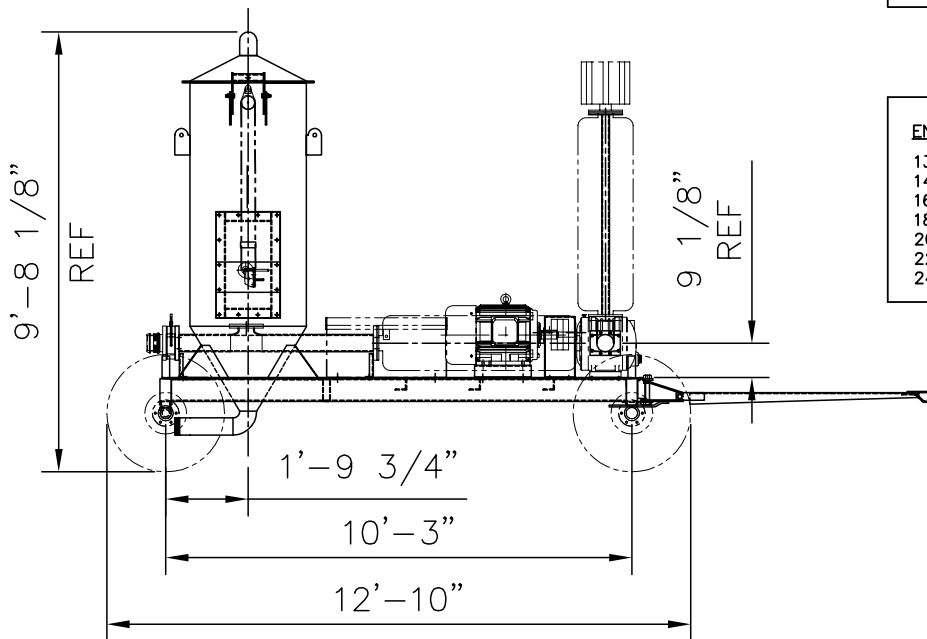

ELEVATION VIEW
SCALE: 1/4"=1'-0"

OPTIONAL DIESEL BLOWER PACK SPECIFICATIONS

ENGINE RPM	BLOWER RPM	BLOWER HP	BLOWER CFM @ 15PSI
1300	2050	50	250
1400	2225	55	300
1600	2540	65	350
1800	2850	70	400
2000	3150	75	500
2200	3500	80	550
2400	3800	85	600

THIS DRAWING, CONCEPTS, AND DESIGNS SHOWN THEREON ARE THE EXCLUSIVE PROPERTY OF RBT SERVICES, INC AND ARE NOT TO BE USED OR REPRODUCED IN WHOLE OR IN PART, WITHOUT THE WRITTEN CONSENT OF RBT SERVICES, INC.

0	04/05/03	RELEASED FOR FABRICATION	DWD
REV. #	DATE:	DESCRIPTION:	BY:

RAIL BARGE TRUCK SERVICES, INC.
 218 CORPORATE DRIVE
 ELIZABETHTOWN, KY 42701
 PHONE: (270) 763-6649
 FAX: (270) 763-6653
 e-mail: sales@rbtsi.com

BP1400 WAGON
 WITH 40HP ELECTRIC MOTOR
 & 4506 BLOWER
 PLAN & ELEVATION VIEWS

DRAWN BY: DWD/RDB	DRAWN DATE: 04/02/03	APPROVED BY: BH JR	APPROVED DATE: 04/03/03
CHECKED BY: SWD	CHECKED DATE: 04/02/03	SHEET NUMBER:	OF
CUSTOMER:	JOB NO:	SCALE: 1"=1'-0"	
LOCATION:	DWG NO: BP1400E-GA-01A		